

VDI paper on national perspectives for energy supply and GHG reduction in Germany for the project Future Climate Engineering Solutions

Abstract

Green house gas emission reduction belongs to the most challenging objectives today. For carbon based energy economies with low potential of hydro and solar power like Poland, Germany, or Benelux different ways are possible which are based on the replacement of CO₂ emitting energy carriers and technologies by renewable energy (especially wind power and biomass), carbon capture and storage (CCS) technologies for fossil energy carriers, and nuclear energy. All generation choices have to be considered in combination with energy saving measures and technologies.

Three scenarios for green house gas mitigation of energy supply and use in Germany are discussed. One scenario includes a 50% reduction coupled with nuclear phase out which is at the moment ordered by law. It implies that the use of off shore wind generators and CCS technology. This scenario will be compared with a 50% reduction plan maintaining the present nuclear capacity. It will be shown that a 50% reduction is possible without nuclear power plants but at higher costs.

For the objective of 75% reduction all known energy technologies must be used without any limitations. A reduction of about 67% can be achieved in this way mostly in the power sector. For the last step to 75%, however, tremendous costs will arise in the transportation sector so that completely new technologies have to be introduced.

1. The German situation

Fig. 1 shows the primary energy consumption (PEC) in Germany. About 80% of the emissions come from energy supply and use. About 5.5 EJ of the PEC, that is more than 38%, are used for the generation of net electricity of 1.8 EJ. That is why electricity generation is considered an important element in GHG reduction. This Figure also shows the wide possibilities of increasing the efficiencies in the sectors of transformation and use.

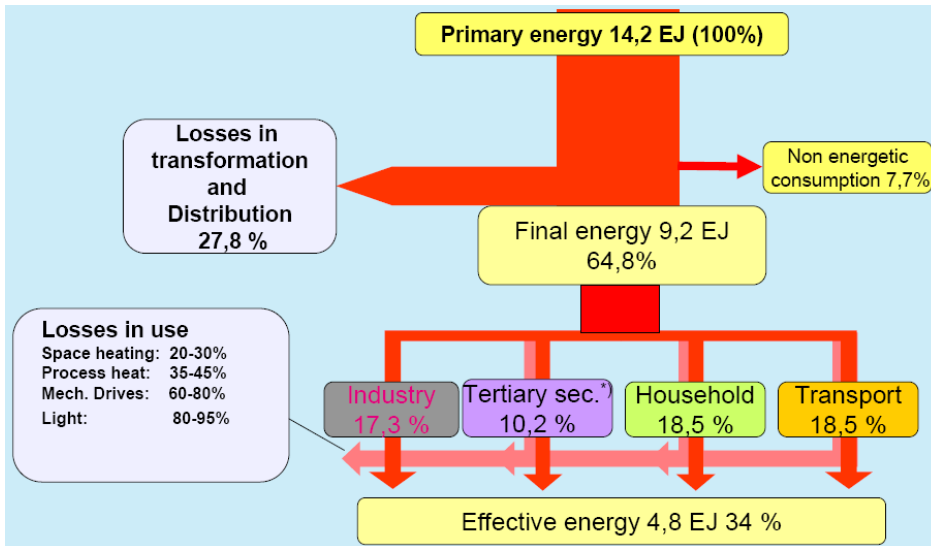

*) small enterprises

Fig 1: Primary energy consumption (PEC) in Germany to obtain effective energy for heating, illumination, and mechanical energy

The primary energy consumption (PEC) is mainly based on fossil (hard coal, lignite, oil and gas) and nuclear fuels. The portion of hydro, biomass and solar source is small due to the geographic situation in Germany. For electricity generation due to German laws, however, the portion of renewable sources exceeds 12% today.

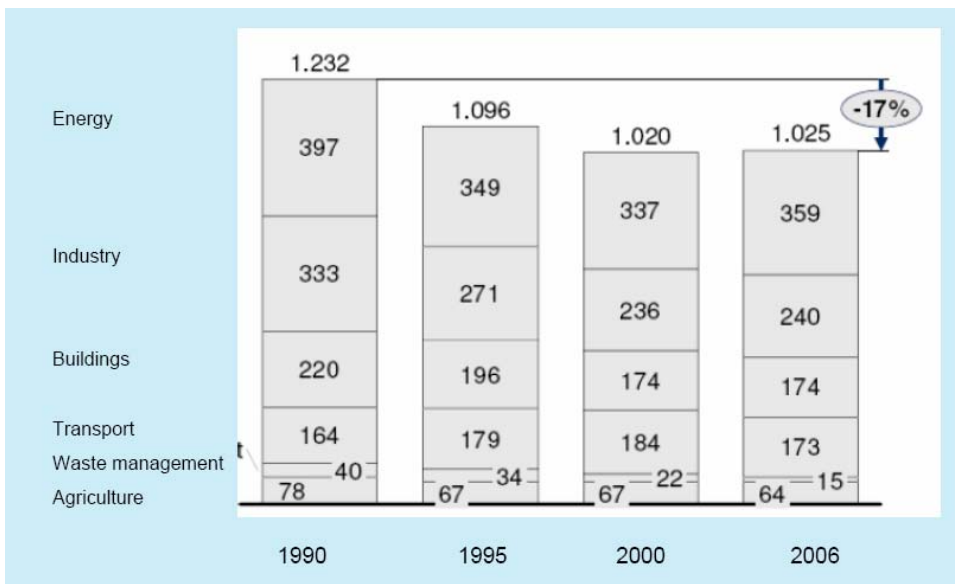

Fig. 2: Composition of GHG emissions in Mt/a [UBA]

Figure 2 shows the composition of GHG emissions in Germany. 209 Mt of 1025 Mt are not energy related: In 240 Mt for industry 130 Mt CO_{2e} come from industrial processes, other 15 Mt come from waste management and 64 Mt from agriculture. These quantities will not be examined further. We assume in our further considerations that the process and waste management emissions will be cut in the same way like energy related emissions.

2. Energy Modelling and basic assumptions

The basic structure of the model is shown in Fig. 3. The model approach is technical oriented. Every energy technology including energy efficiency technology is characterised by inputs and outputs and by efficiency parameters and specific emissions. Energy import prices will be given as input. This optimisation model is reflecting the relations in the network of the German energy supply (which includes the supply as well as the usage of energy from primary energy over final energy to effective energy). Special emphasis is put on the possibilities of savings by increasing efficiencies in the final energy sectors industry, small consumer, transport, and households. The energy flow from primary energy to effective energy will be described by energy sources and energy services. Effective energy is represented by the demand for energy services, for instance for space heating, tons and personal kilometres or industrial goods.

The specific costs per technology in the different sectors are taken from different reliable sources. Especially assumptions for these costs in the years 2040 and 2050 are best extrapolations but have to be revisited with time as a specific example cost for power generating equipment was compared with various German utilities and VGB (Association of Power Plant Operators).

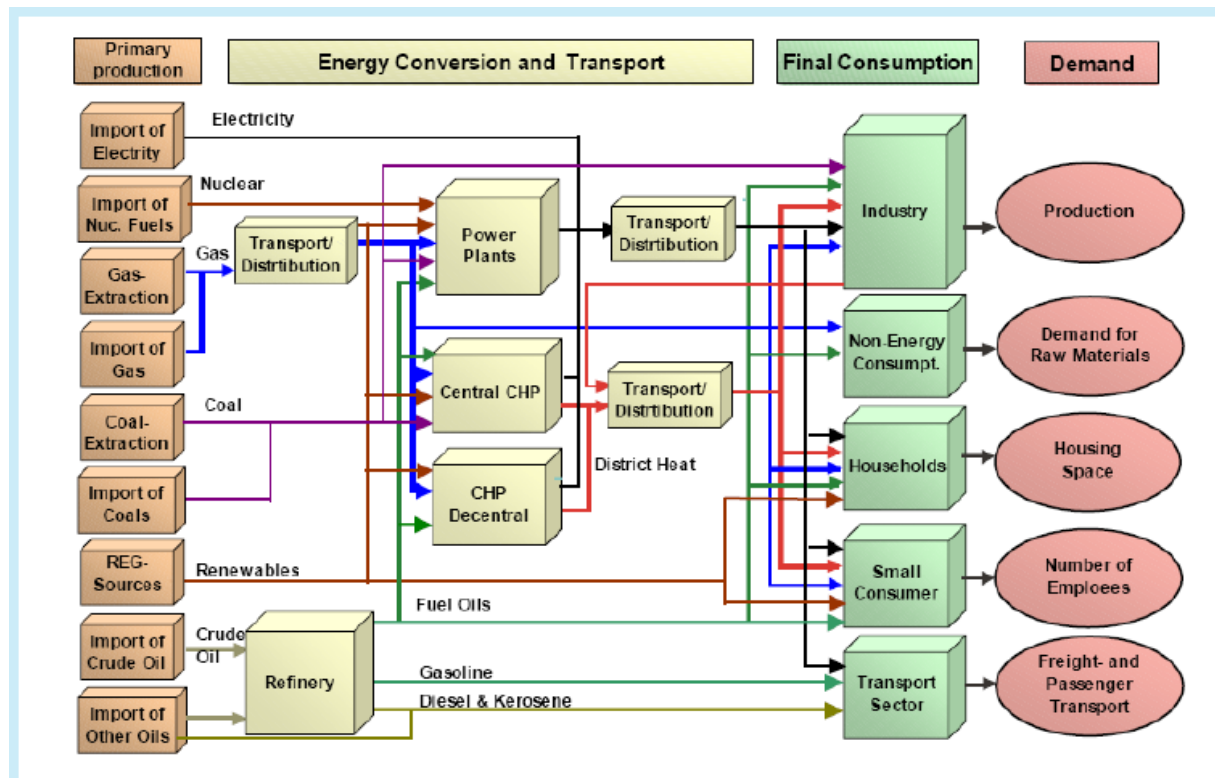

Fig. 3: Energy system modelling at Jülich Research Center (IKARUS-LP)

The mathematical method of linear programming (LP) in the form of a time-step model is used. The energy system will be optimized by minimizing the total costs of the economic system. In this way the model will calculate a special combination of technologies and energy sources taking given parameters and technology data as boundary conditions into account.

The basic assumptions for the boundary conditions are shown in Fig. 4 to 6. They are taken from various prediction models and have been evaluated by the VDI team. Members of the VDI Society of Energy and Environment as well as VDI experts from the transportation sector and building services have been involved.

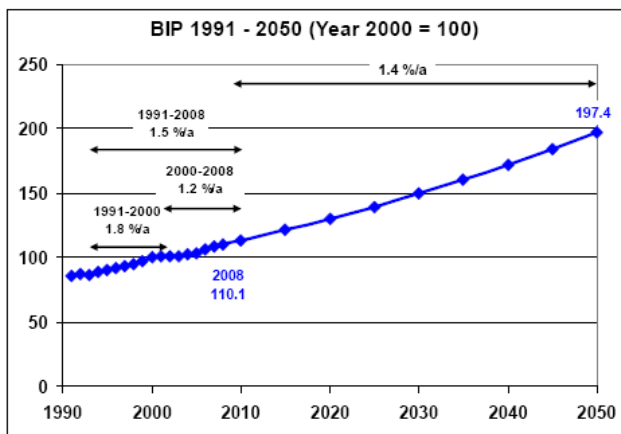

Fig. 4: Gross domestic product: Development until 2008 and prognosis

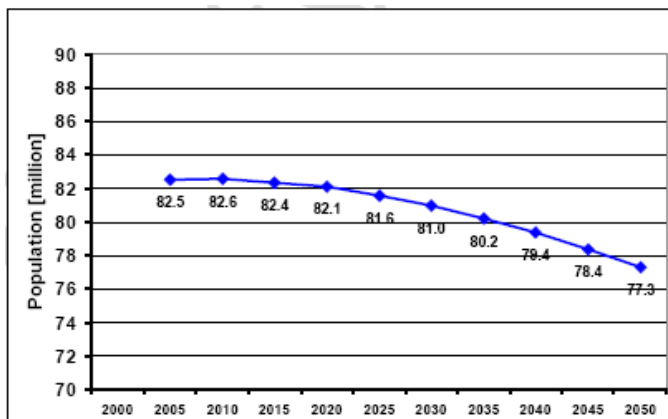

Fig 5: Prognosis of demographic development

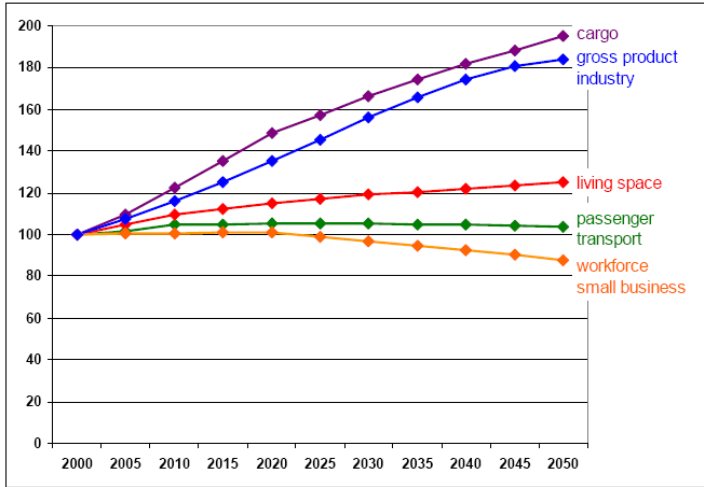

Fig 6: Prognosis of demand figures in the transport sector (cargo, passenger transport), domestic sector (living space), and small enterprises sector (workforce) and in the industry sector (gross product)

Fig. 7 shows the two price scenarios for energy imports at low and high prices for Plans A&B and C.

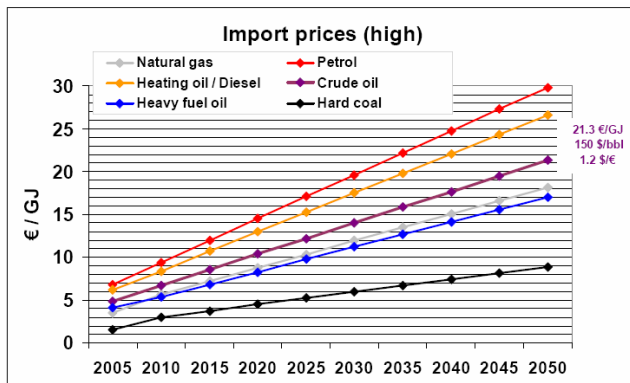
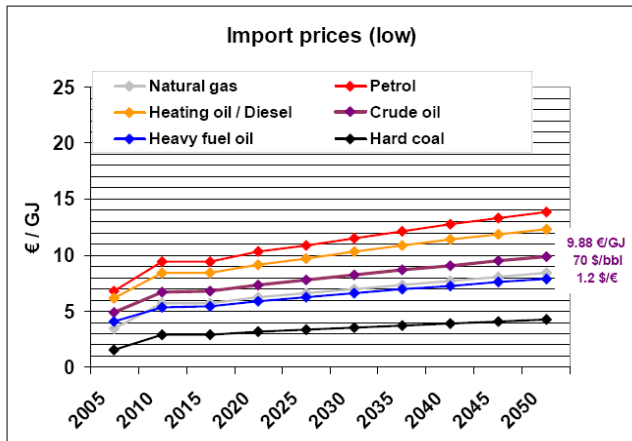

Fig. 7: Estimation of import prices for energy

Figure 8 sets plausible upper limits of electricity generation capacity. The model will optimize the total system for lowest cost until one of the limits set for generation capacity is hit; from thereon it will be held constant.

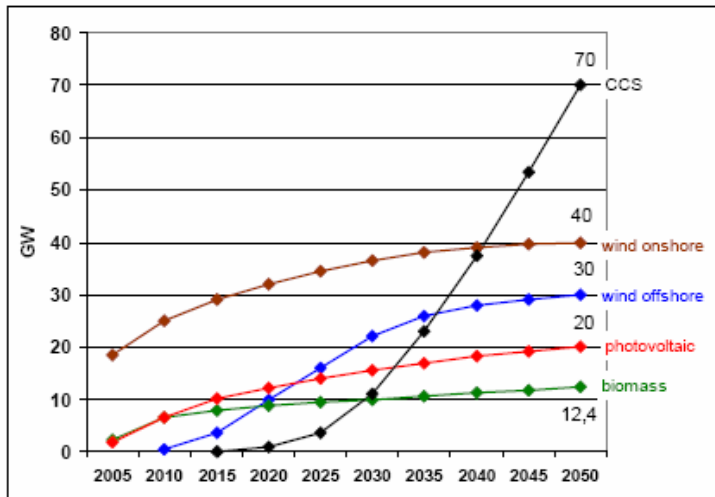

Fig. 8: Upper limits for electricity generation capacity

The import of electricity from other countries as well as from solar thermal power plants in the south of Spain or in North Africa will not be considered as well as electricity from nuclear fusion.

A special issue is the use of nuclear power. In Fig. 9 two options are shown. According to German law nuclear power plants will have to be shutdown at about 2020. This decision was made in 2000 to keep social peace in Germany due to protest actions against nuclear power plant operation.

At present, the public opinion concerning nuclear energy is split but may become very important due to the necessity of GHG reduction, so a “nuclear maintaining scenario” is proposed which will keep the present capacity of 20 GW by life time extension up to 60 year and the possibility of replacement (Plan B).

Nuclear phase out (Plan A)

Maintaining nuclear capacity and 60 years life time (Plan B)

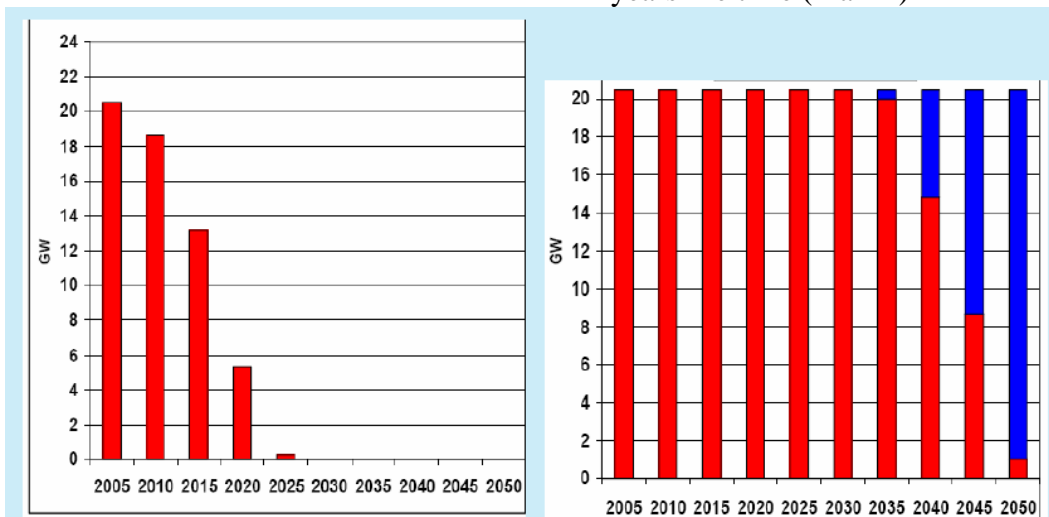

Fig. 9: Two possibilities for nuclear future in Germany

The assumptions for the transport sector are based upon estimations of the responsible Federal Ministry and shown in Fig. 10.

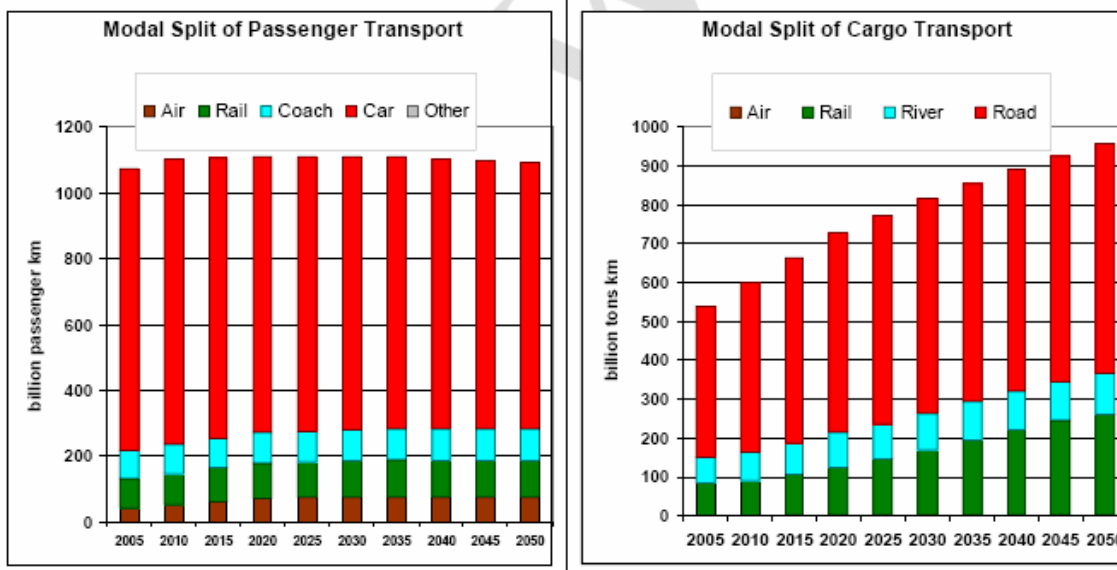

Fig. 10 Composition of personal transport and cargo

Basic assumptions for the modelling of the energy consuming sectors are shown in Table 1.

Sector	Assumptions
Industry	<ul style="list-style-type: none"> • Further improvement of energy efficiency in the present trend in 22 industrial branches • Decrease of the portion of energy intensive industry • Further measures for saving process heat and electricity consumption
Small enterprises	<ul style="list-style-type: none"> • Subdivision into 6 branches with consumption of space and process heat, light, communication, and power
Households	<ul style="list-style-type: none"> • Dynamic distribution of the area in family and multi-family houses, old and new buildings – also regarding old buildings in renovatiuon cycles • Consideration of energy saving regulations (EnEV) 2010 and a stronger one in 2020 • Further decrease of heat consumption • Reduction of electricity consumption
Transport	<ul style="list-style-type: none"> • Max. average emissions for new cars must not exceed 120 g/km starting in 2020 with similar restrictions for lorries • Dynamic distribution of local and intercity transport and modal split • The portion of rail transport of goods will increase clearly

Table 1: Assumptions for the sectors

3. Reference scenarios

The three Reference scenarios for Plans A, B and C, that is without an imposed CO₂ reduction target, do include the implementation of all economic measures for energy saving and CO₂ reduction as well as the implementation of all expected compulsory measures. An overview is given in Table 2.

Reference scenario	Characteristic	CO ₂ -reduction 2050	Final energy savings
LN	Low energy prices, preservation nuclear capacity	-33%	-26%
HN	High energy prices, preservation nuclear capacity	-39%	-29%
HP	High energy prices, nuclear phase out	-34%	-28%

Table 2: Overview of the reference scenarios calculated

Sector	Total decrease 2005-2050	Measures
Households Small Enterprises	38-39% 33-37%	Compulsory (new EnEV -energy savings regulation- in 2020), use of renewable energy, decreasing energy consumption for cooking, washing, cooling etc.
Industry	24-29%	Efficiency improvements Decreasing portion of energy intensive branches Further measures reducing heat and electricity consumption
Transport	11-14%	120 g/km for new cars, increase of LPG and CNG drives, hybrid plug-in

Table 3: Final energy consumption in reference scenarios

In this way, the CO₂-emissions can be reduced 33% (low prices) or 39% (high prices). These reference scenarios form the basis of the CO₂ scenarios described below. Costs of CO₂ scenarios are referred to the costs of the reference scenarios.

Fig. 11 shows the structure of generation capacity and electricity production for the three reference scenarios. After 2035 the possibility of replacing old by new nuclear power plants will always be taken for Scenarios LN and HN. In case of nuclear phase out scenario LP this electricity will be replaced by generation from coal, biomass, and wind with gas for back up.

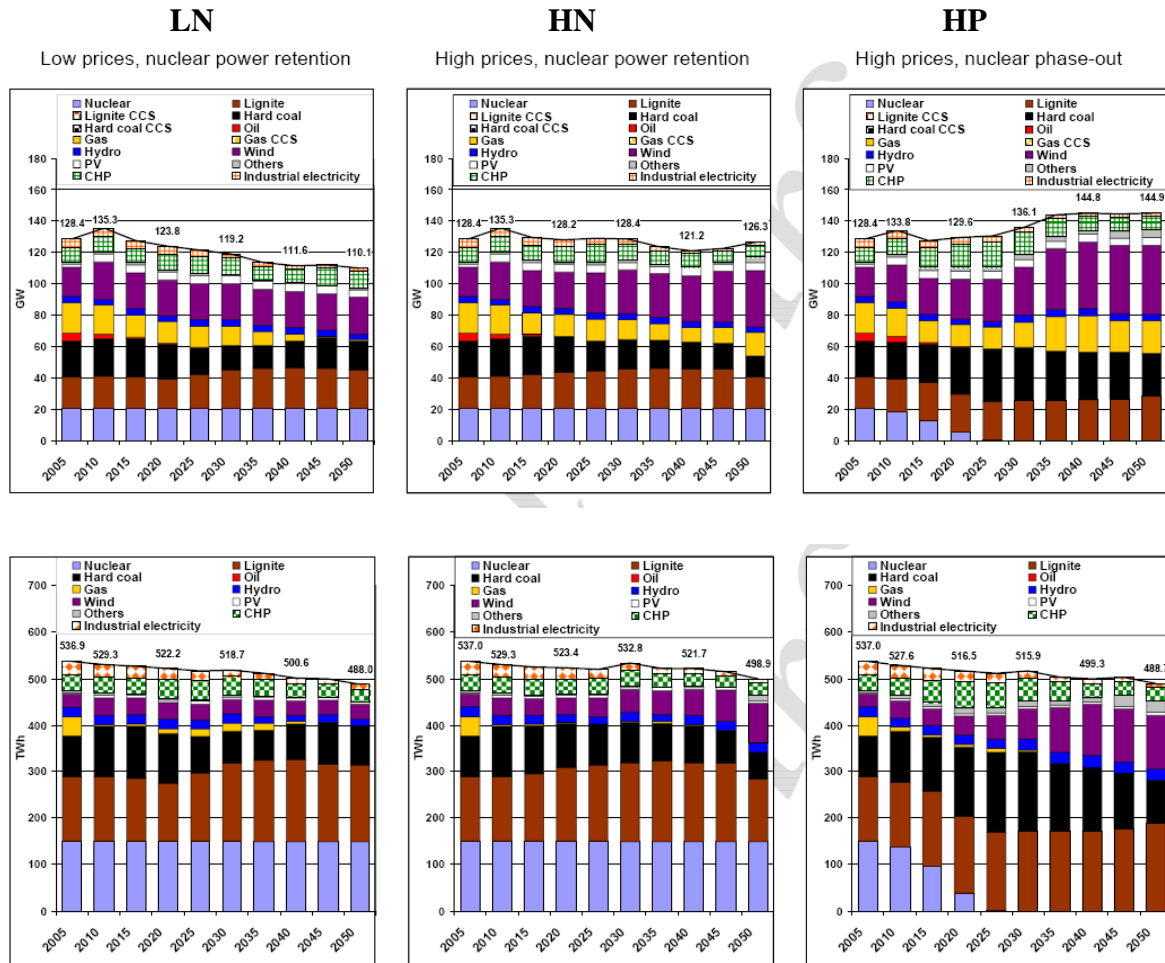

Fig. 11: Capacity and electricity generation in reference scenarios

4. National energy and climate plans for Germany: Basic results

On the basis of these reference scenarios the following energy plans for Germany are discussed:

Plan A: 50% reduction of energy related GHG-emissions with nuclear phase out at high energy import prices

Plan B: 50% reduction of energy related GHG-emissions with nuclear power retention at high energy import prices

Plan C: 75% reduction of energy related GHG-emissions with all options at low energy import prices

The results of the calculation are presented in Fig. 12 to 28.

For comparison a further low price 50% scenario with nuclear retention is also presented. Due to possible changes of economic, ecological, and social kind all plans should be revisited with time.

Plan A: 50 % CO₂ mitigation scenario, nuclear phase-out

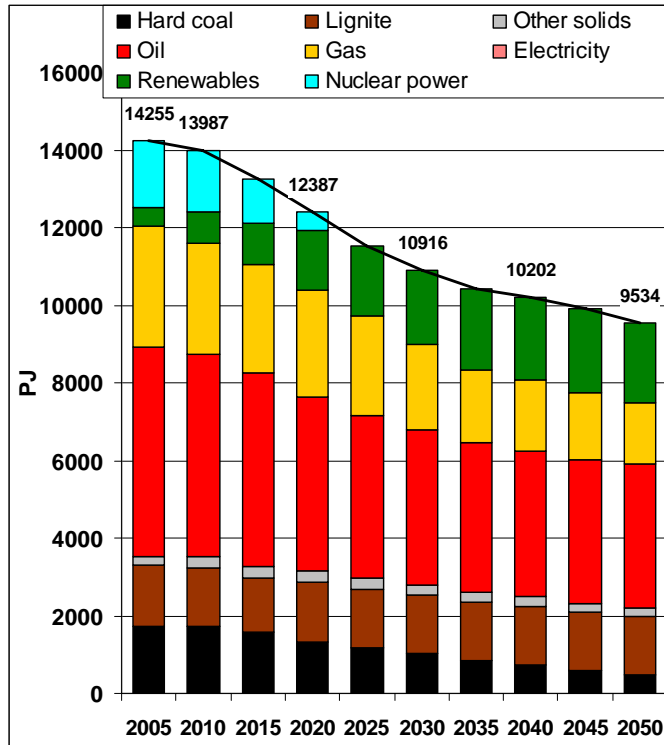

Plan B: 50 % CO₂ mitigation scenario, nuclear power retention

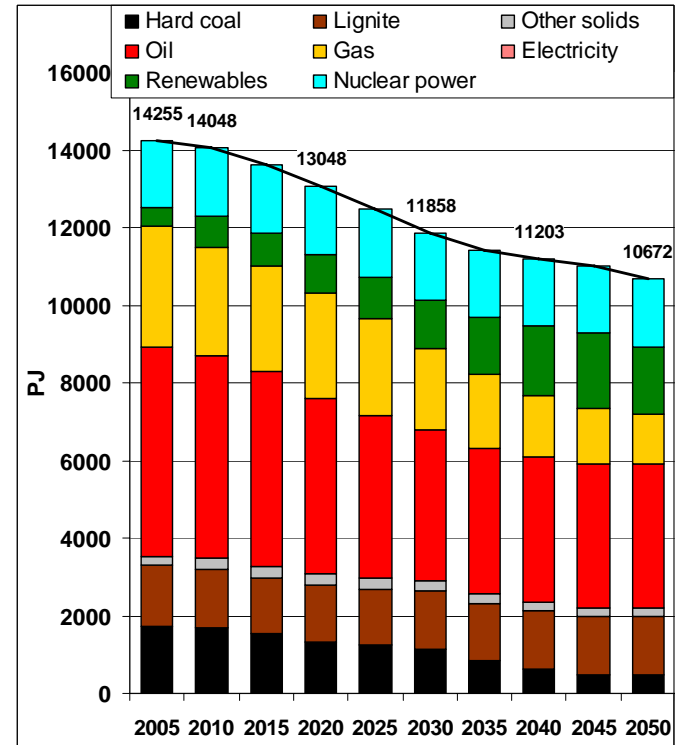
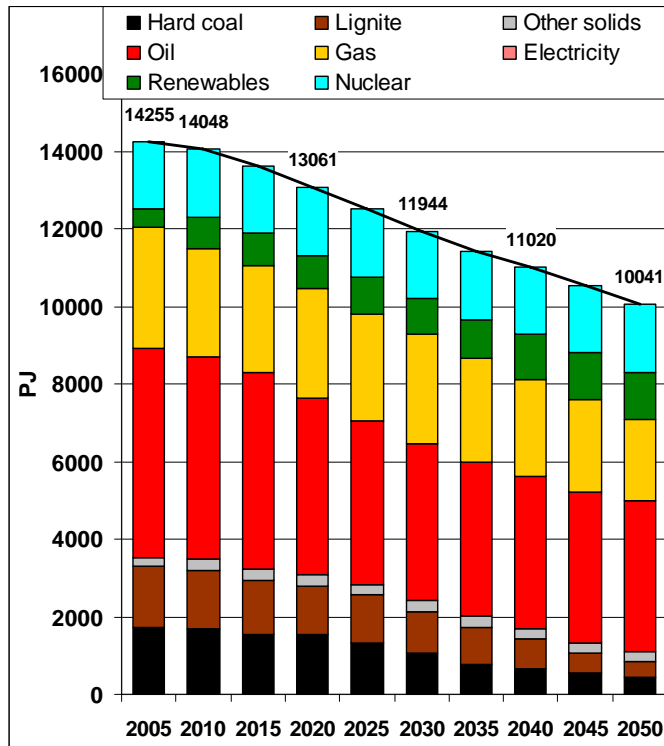

Figure 12: Alternative scenarios for high imported energy carriers prices; primary energy consumption: 50 % CO₂ mitigation scenario with nuclear phase-out vs. 50 % CO₂ mitigation scenario with nuclear power retention vs.

50 % CO₂ mitigation scenario, nuclear power retention



Plan C: 75 % CO₂ mitigation scenario, nuclear power new building

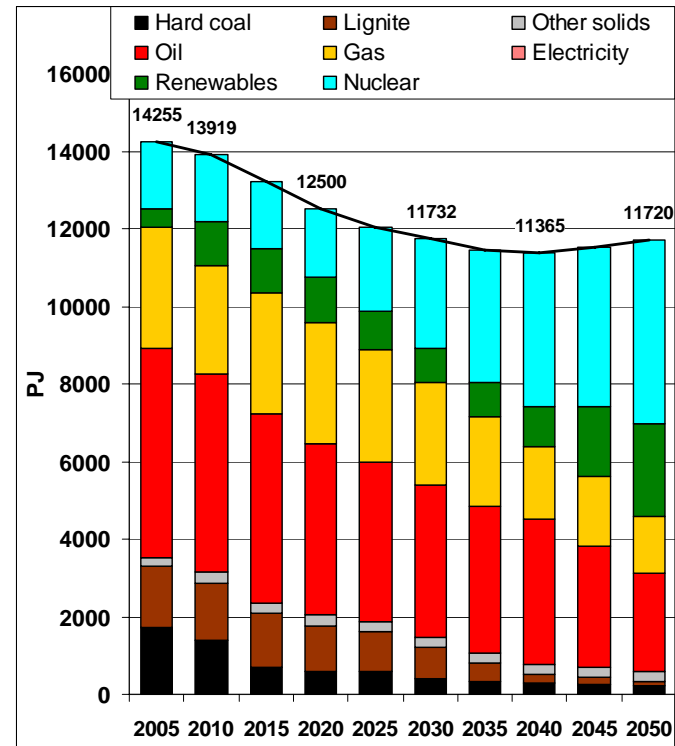
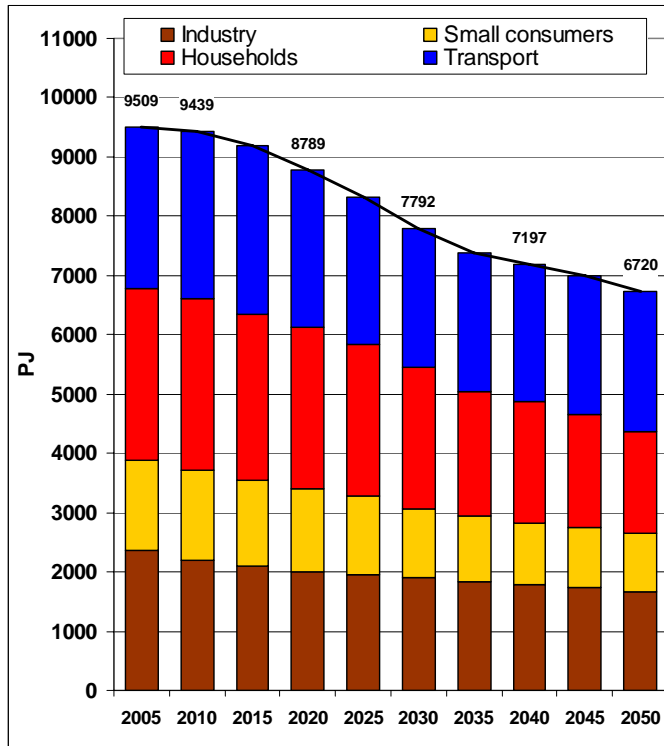

Figure 13: Alternative scenarios with low imported energy carriers prices; primary energy consumption: 50 % mitigation scenario with nuclear power retention vs. 75 % mitigation scenario with nuclear power new buildings

Plan A: 50 % CO₂ mitigation scenario, nuclear phase-out



Plan B: 50 % CO₂ mitigation scenario, nuclear power retention

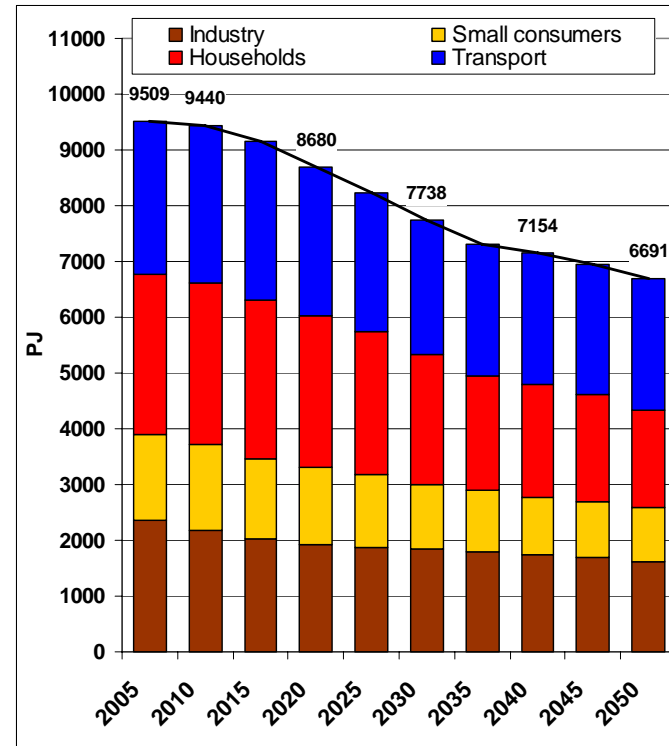
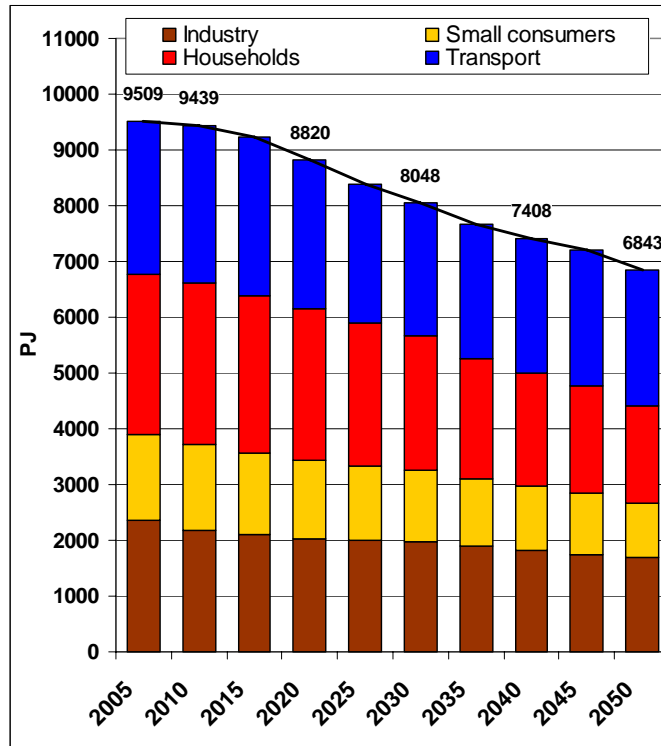

Figure 14: Alternative scenarios for high imported energy carriers prices; total end energy consumption: 50 % CO₂ mitigation scenario with nuclear phase-out vs. 50 % CO₂ mitigation scenario with nuclear power retention

50 % CO₂ mitigation scenario, nuclear power retention



Plan C: 75 % CO₂ mitigation scenario, nuclear power new building

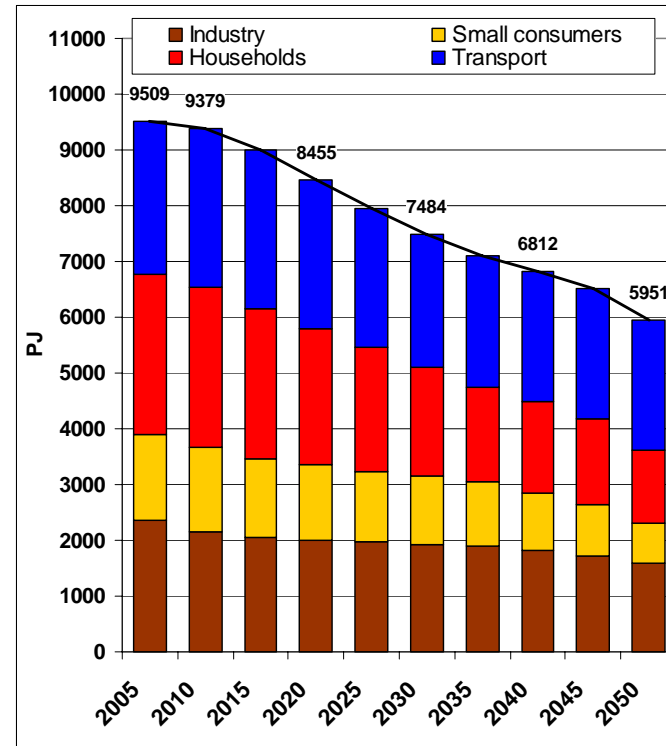

Figure 15: Alternative scenarios with low imported energy prices; total end energy consumption: 50 % mitigation scenario with nuclear power retention vs. 75 % mitigation scenario with nuclear power new buildings

Plan A: 50 % CO₂ mitigation scenario, nuclear phase-out

Plan B: 50 % CO₂ mitigation scenario, nuclear power retention

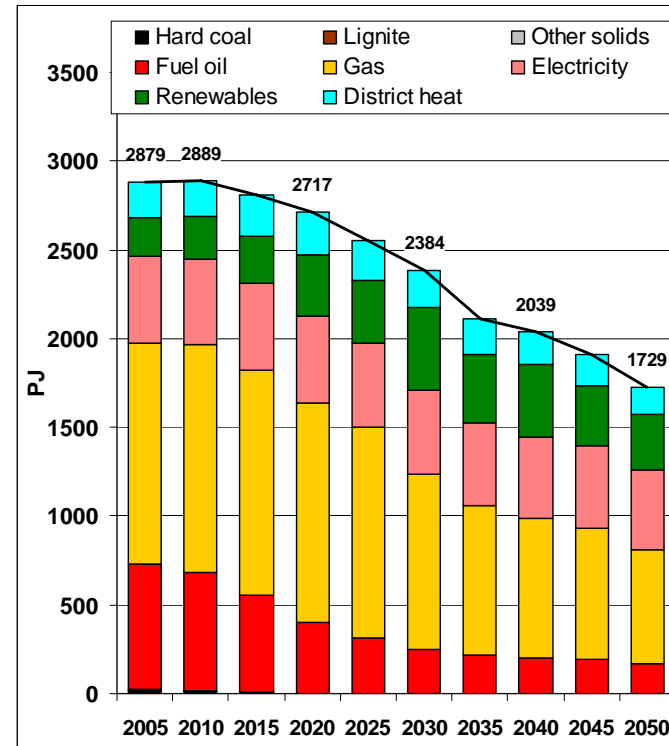
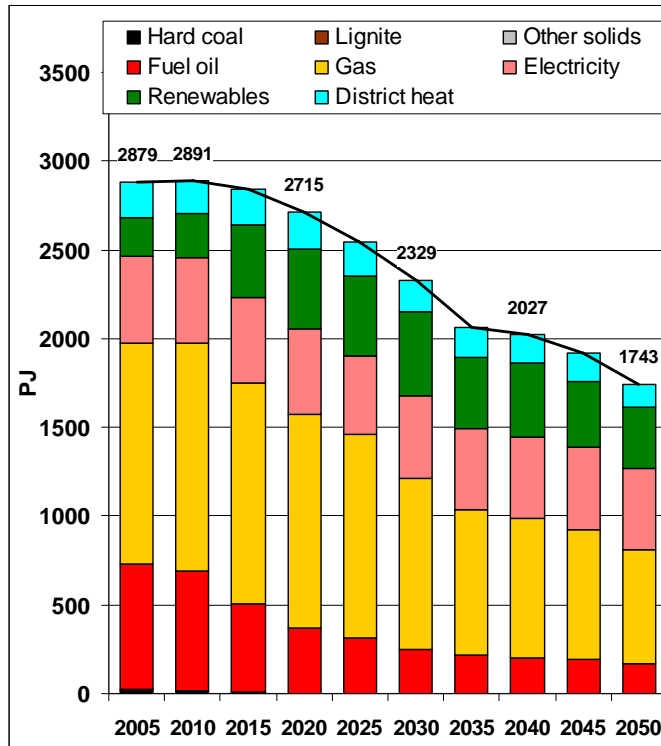
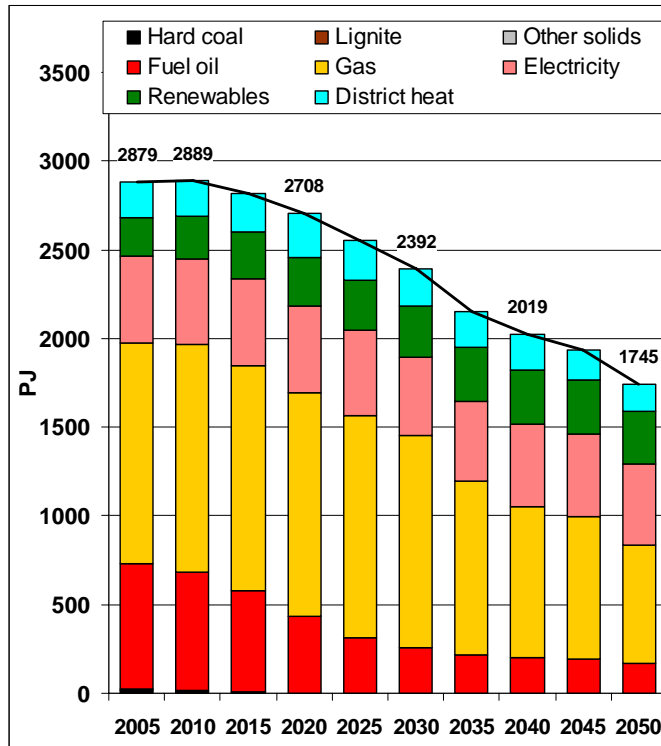

Figure 16: Alternative scenarios for high imported energy carriers prices; end energy consumption of the households sector: 50 % CO₂ mitigation scenario with nuclear phase-out vs. 50 % CO₂ mitigation scenario with nuclear power retention

50 % CO₂ mitigation scenario, nuclear power retention



Plan C: 75 % CO₂ mitigation scenario, nuclear power new building

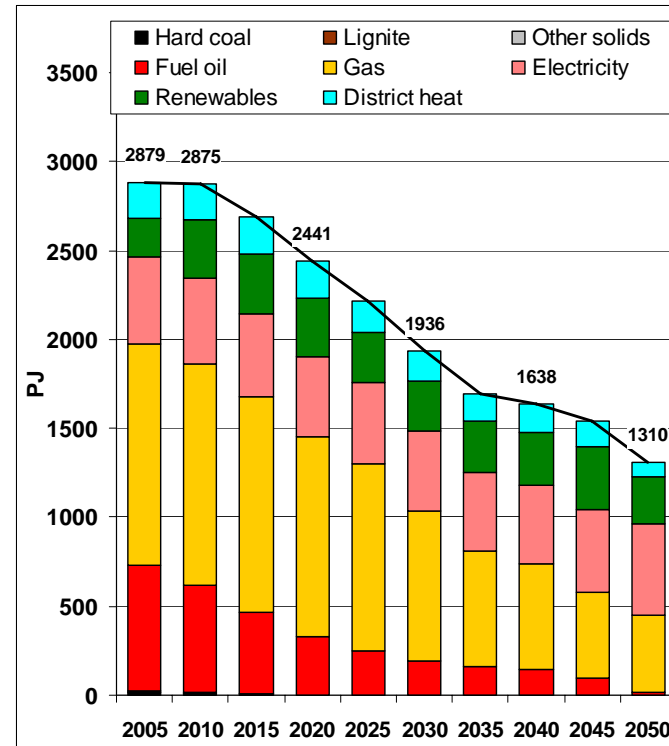

Figure 17: Alternative scenarios with low imported energy prices; end energy consumption of the households sector: 50 % mitigation scenario with nuclear power retention vs. 75 % mitigation scenario with nuclear power new buildings.

Plan A: 50 % CO₂ mitigation scenario, nuclear phase-out

Plan B: 50 % CO₂ mitigation scenario, nuclear power retention

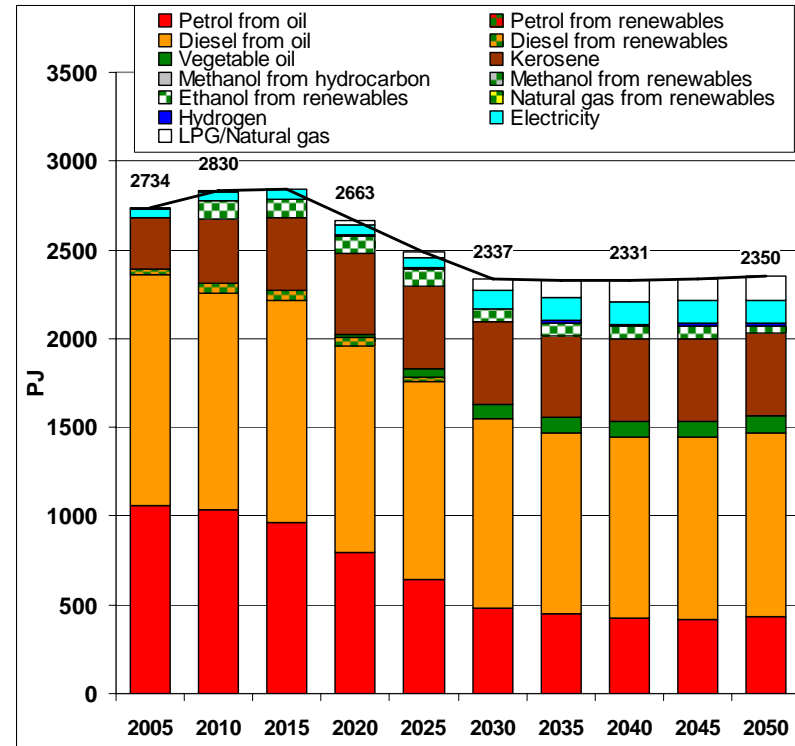
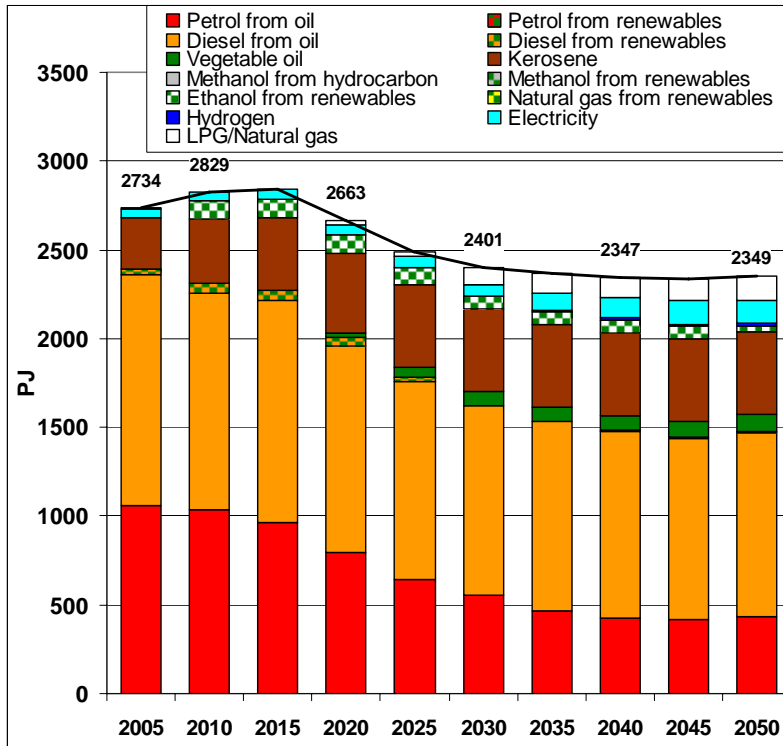
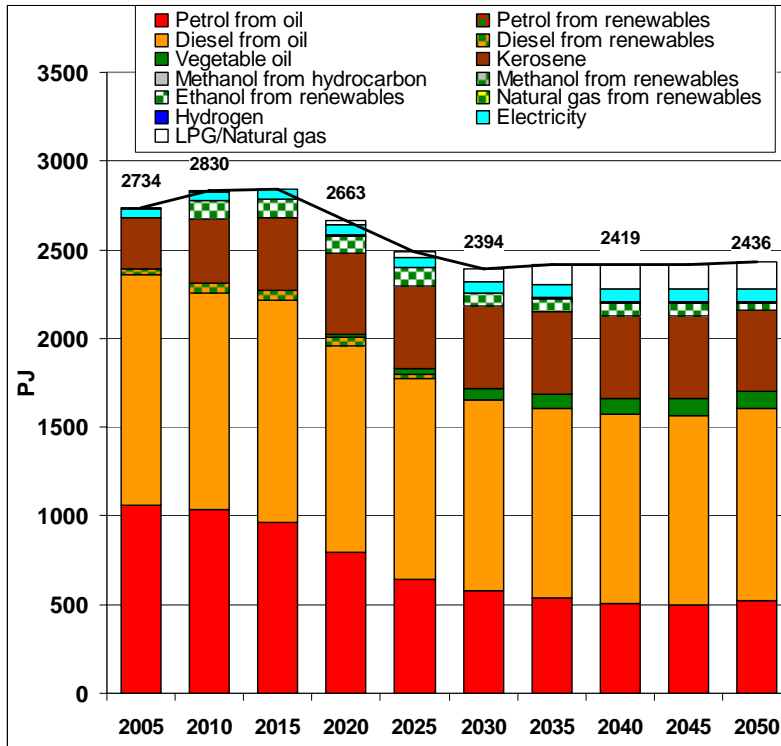

Figure 18: Alternative scenarios for high imported energy carriers prices; end energy consumption of the transport sector: 50 % CO₂ mitigation scenario with nuclear phase-out vs. 50 % CO₂ mitigation scenario with nuclear power retention

50 % CO₂ mitigation scenario, nuclear power retention



Plan C: 75 % CO₂ mitigation scenario, nuclear power new building

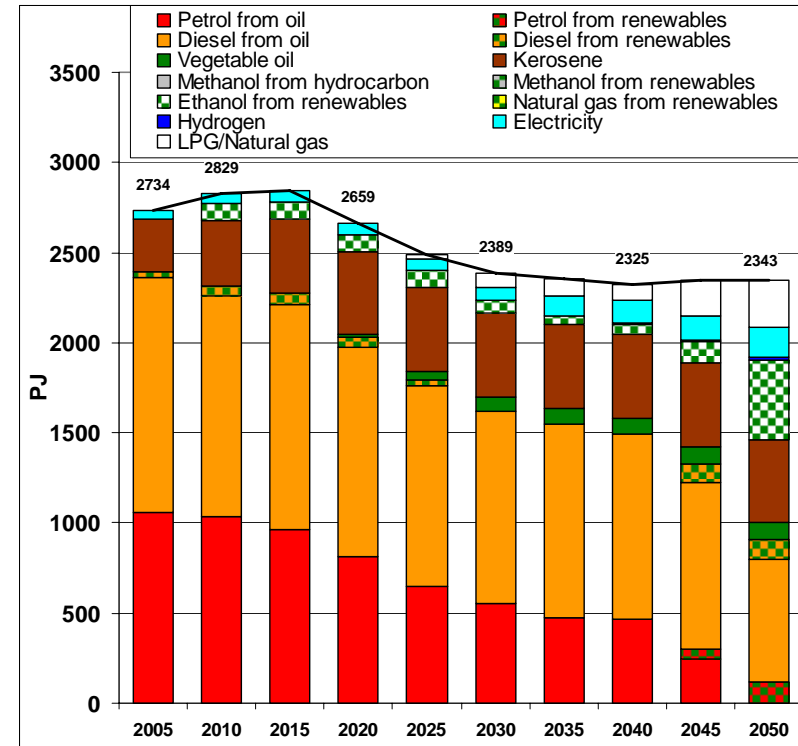
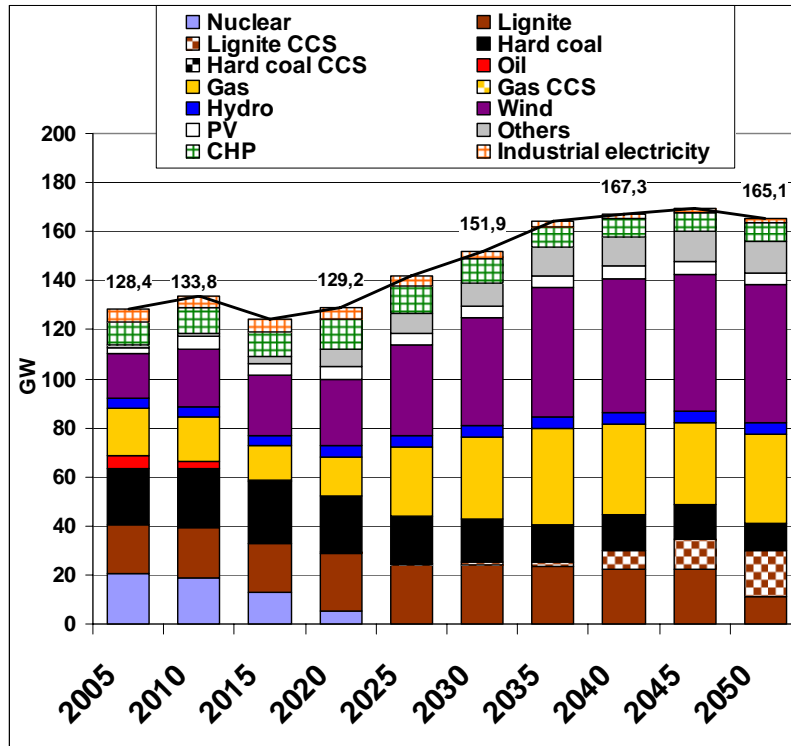

Figure 19: Alternative scenarios with low imported energy prices; end energy consumption of the transport sector: 50 % mitigation scenario with nuclear power retention vs. 75 % mitigation scenario with nuclear power new buildings

Plan A: 50 % CO₂ mitigation scenario, nuclear phase-out



Plan B: 50 % CO₂ mitigation scenario, nuclear power retention

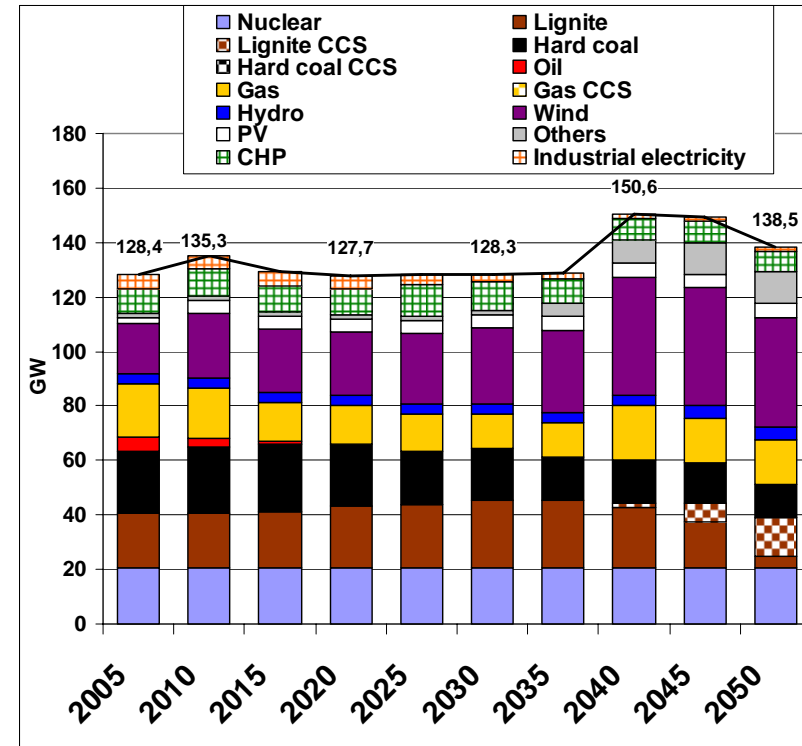
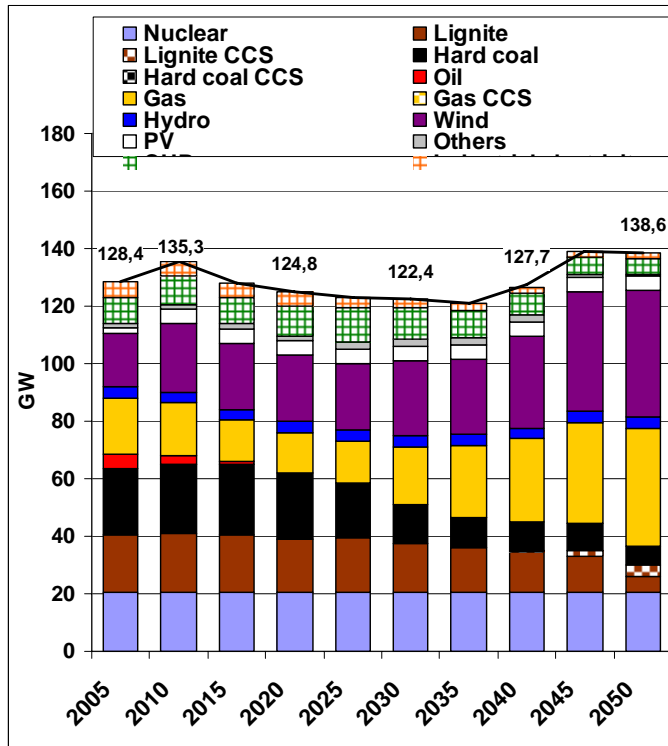

Figure 20: Alternative scenarios for high imported energy carriers prices; net output capacity of the electricity sector: 50 % CO₂ mitigation scenario with nuclear phase-out vs. 50 % CO₂ mitigation scenario with nuclear power retention

50 % CO₂ mitigation scenario, nuclear power retention



Plan C: 75 % CO₂ mitigation scenario, nuclear power new building

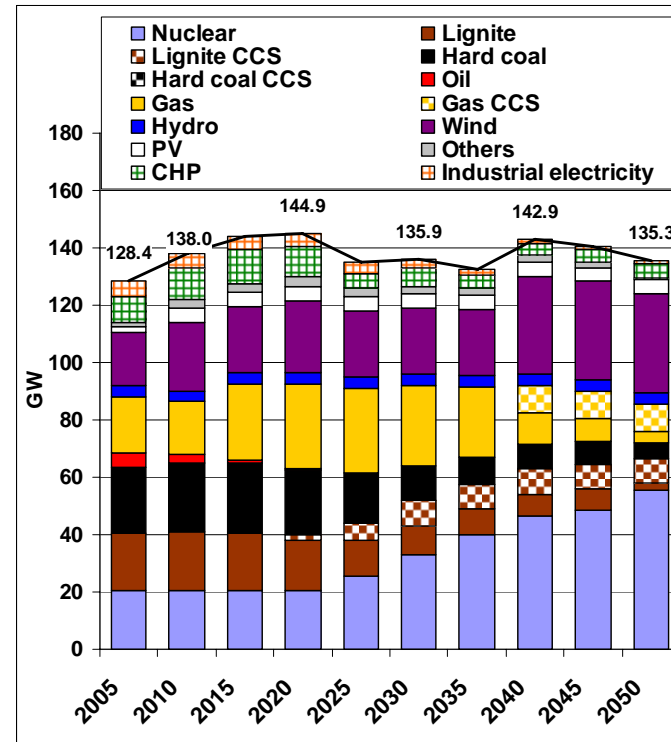
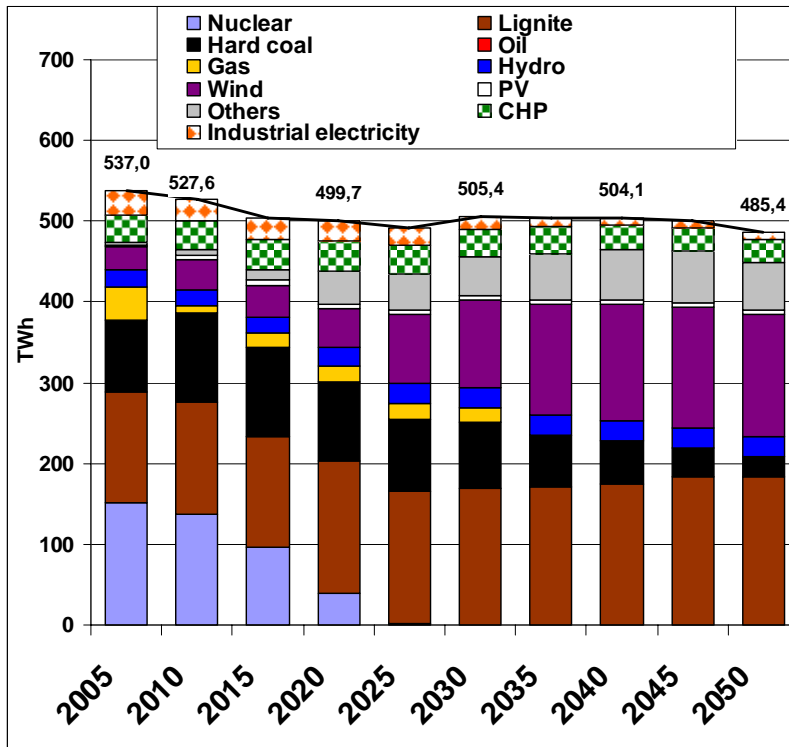

Figure 21: Alternative scenarios with low imported energy prices; net output capacity of the electricity sector: 50 % mitigation scenario with nuclear power retention vs. 75 % mitigation scenario with nuclear power new buildings

Plan A: 50 % CO₂ mitigation scenario, nuclear phase-out



Plan B: 50 % CO₂ mitigation scenario, nuclear power retention

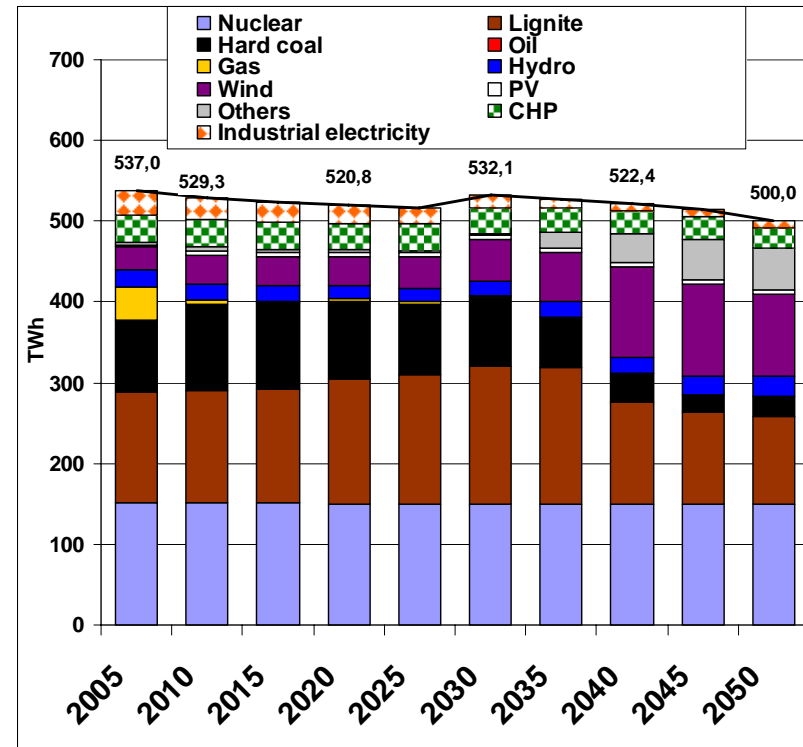
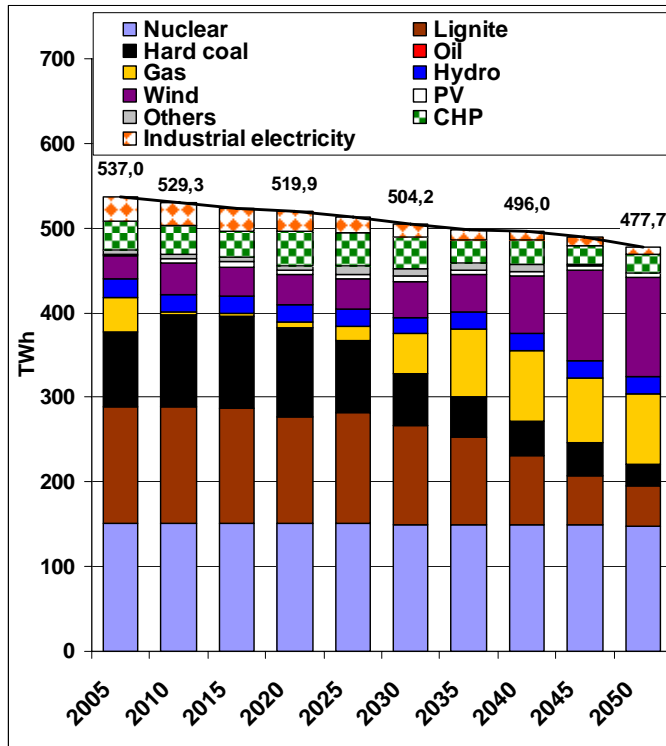

Figure 22: Alternative scenarios for high imported energy carriers prices; net electricity generation of the electricity sector: 50 % CO₂ mitigation scenario with nuclear phase-out vs. 50 % CO₂ mitigation scenario with nuclear power retention

50 % CO₂ mitigation scenario, nuclear power retention



Plan C: 75 % CO₂ mitigation scenario, nuclear power new building

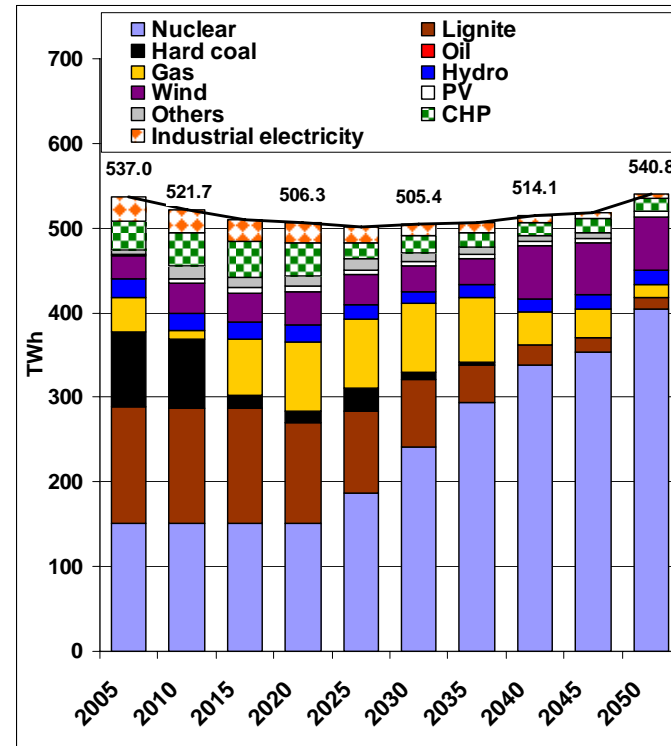
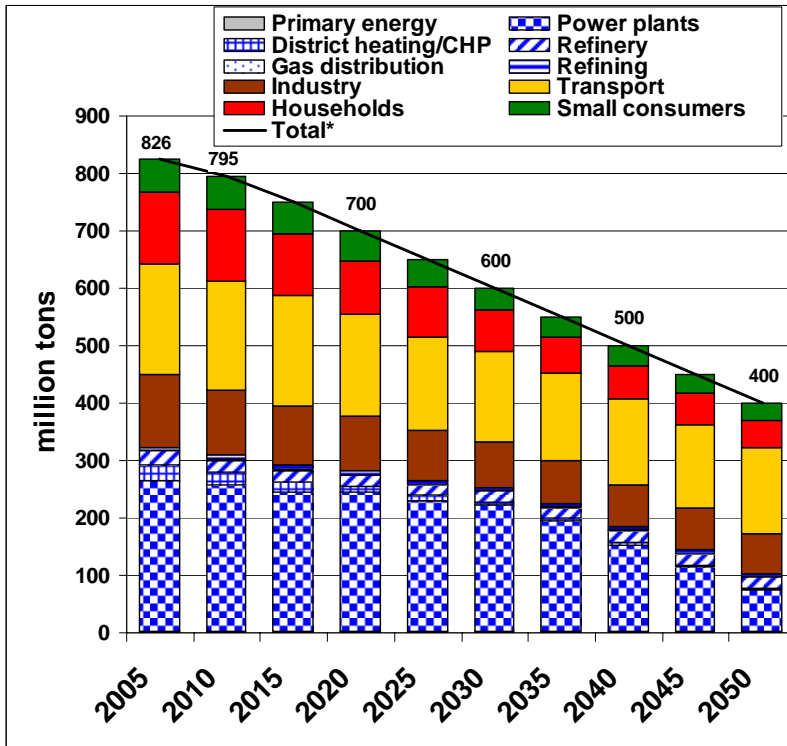

Figure 23: Alternative scenarios with low imported energy prices; net electricity generation of the electricity sector: 50 % mitigation scenario with nuclear power retention vs. 75 % mitigation scenario with nuclear power new buildings

Plan A: 50 % CO₂ mitigation scenario, nuclear phase-out



Plan B: 50 % CO₂ mitigation scenario, nuclear power retention

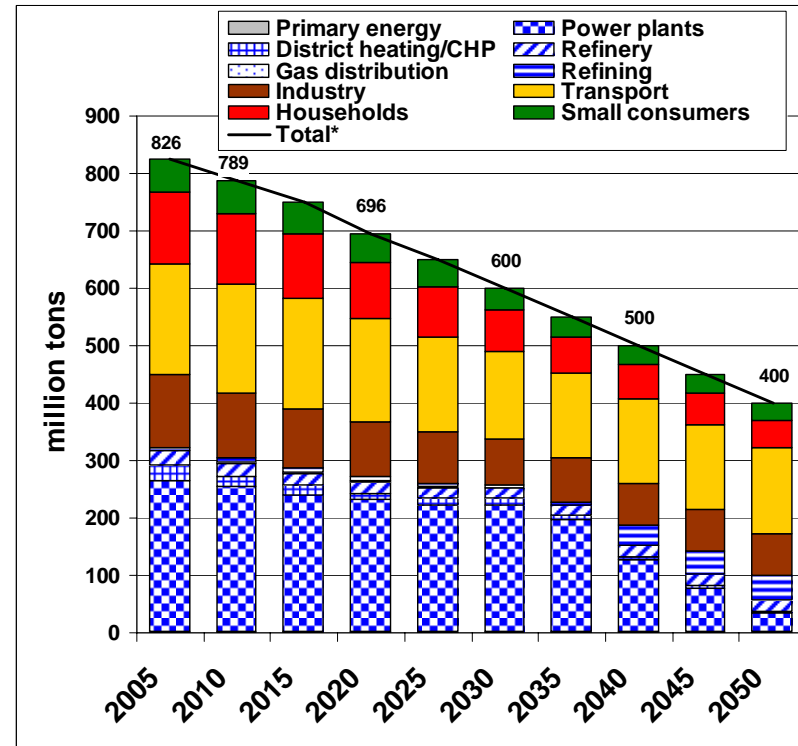
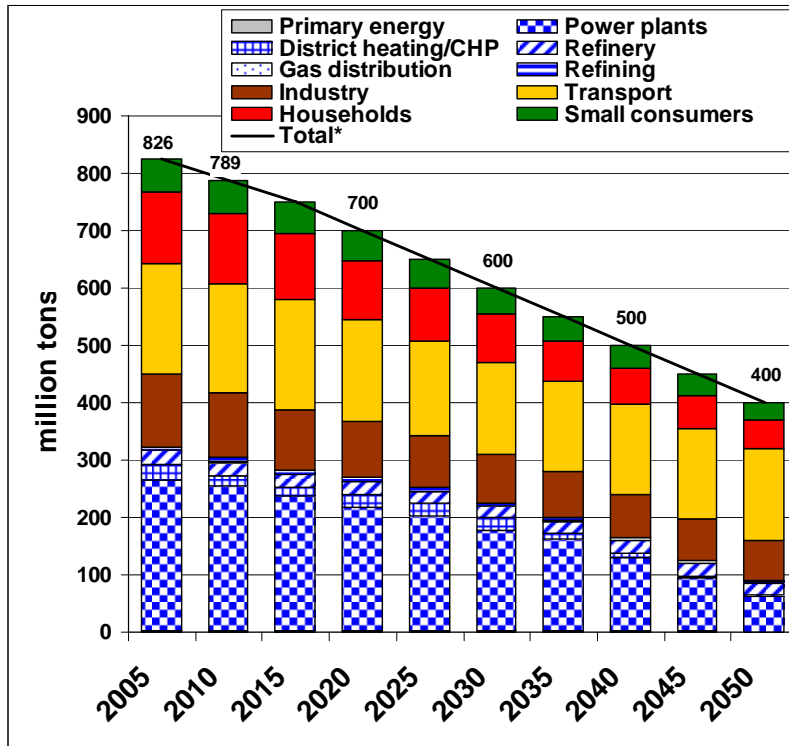

Figure 24: Alternative scenarios for high imported energy carriers prices; CO₂ emissions: 50 % CO₂ mitigation scenario with nuclear phase-out vs. 50 % CO₂ mitigation scenario with nuclear power retention

50 % CO₂ mitigation scenario, nuclear power retention



Plan C: 75 % CO₂ mitigation scenario, nuclear power new building

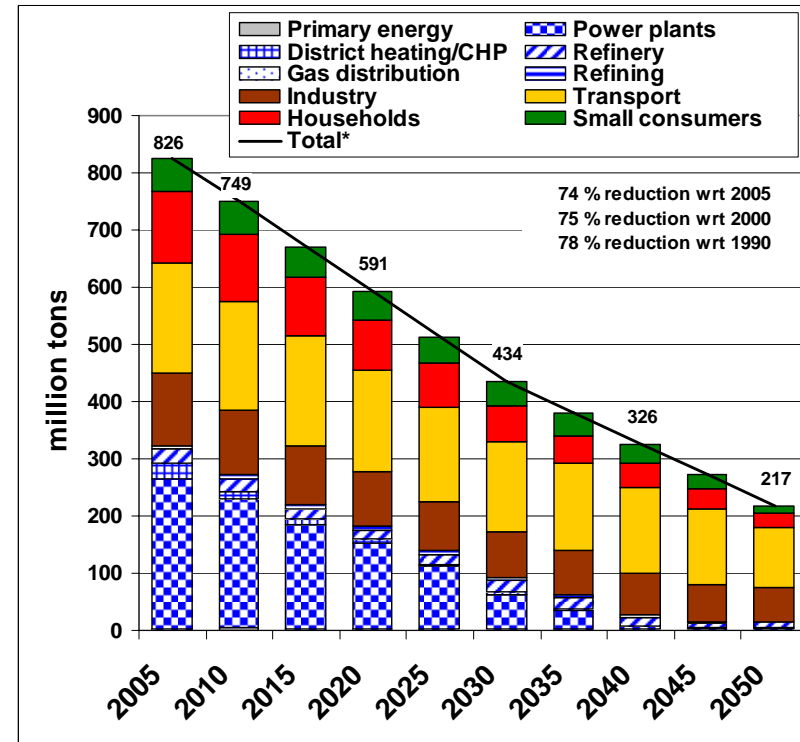

Figure 25: Alternative scenarios with low imported energy prices; CO₂ emissions: 50 % mitigation scenario with nuclear power retention vs. 75 % mitigation scenario with nuclear power new buildings

5. Evaluation of energy plans

From the technical point of view, not looking at economics, all scenarios can be feasible. Regarding costs and burdens for special industrial branches and the jobs therein, the scenarios calculated are quite different (Fig. 26).

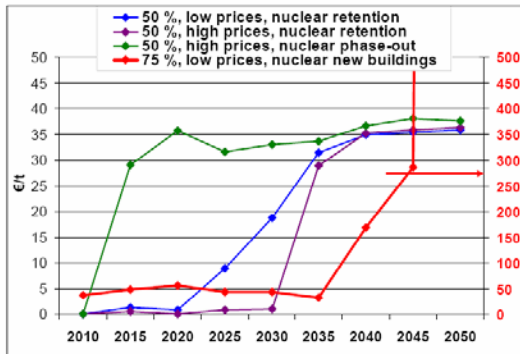

Fig. 26: CO₂ Reduction costs compared with reference

Baseline 2005

	Sector				
	Energy	Industry	Tertiary	Household	Transport
Energy consumption PJ	3699	2359	1536	2880	2734
CO ₂ emissions Mt	323	126	59	124	194

Plan A (2050)

Efficiency and CO₂ reduction parameters

	Sector				
	Energy	Industry	Tertiary	Households	Transport
Reduction of energy consumption	-51%	-31%	-37%	-39%	-14%
Reduction of CO ₂ emissions	-68%	-44%	-49%	-61%	-23%

Problems:

- Carbon capture and storage technology (there are no regulations for CO₂ storage sites today)
- Offshore wind generators have to be installed under conditions (depth 25-35 m, distance to coast 90 km, wave amplitude 10 m)

Plan B (2050)

	Sector				
	Energy	Industry	Tertiary	Households	Transport
Reduction of energy consumption	-21%	-29%	-37%	-47%	-14%
Reduction of CO ₂ emissions	-68%	-44%	-49%	-61%	-23%

Without looking at the energy sector, the values are almost the same, however, the total costs are 220 billion € lower than in plan A (Fig. 27). Otherwise, the above mentioned problems of plan A are not so severe.

Further, the generation costs for electricity will be considerably higher in plan A than in plan B as the generation mix in Fig. 20 indicates.

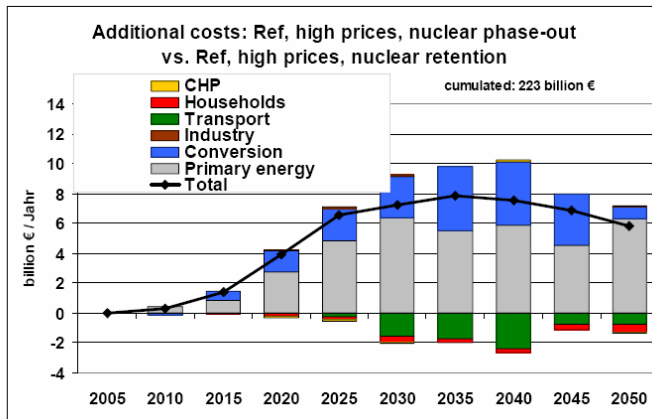

Fig. 27: Costs for nuclear phase out

Plan C (2050)

In order to achieve even higher CO₂-reductions an “all options scenario” (Plan C) was examined which also includes the further use of nuclear fission energy. Since the generation costs are much lower, 34 plants of EPR type (1650 MW) will be built until 2050 (30 until 2045) with the result that electricity generation will be almost CO₂-free (see Fig. 25). Further CO₂ reductions have to come from especially from the freight transport sector. This sector causes the main part of the additional costs of approximately 243 bill. €/a between 2045 and 2050 (Fig.28).

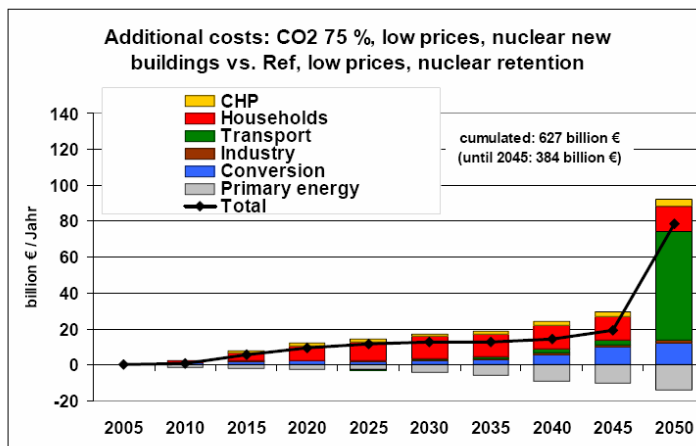

Fig. 28: Costs on the path to a 75% scenario

CO₂ mitigation costs increase from 280 €/t in 2045 to 10.000€/t in 2050 (Fig. 26, red line).



For this reason, the possibilities for mitigating CO₂ emissions known today are limited to 271 Mt/a (67% of the 2005 emissions).

	Sector				
	Energy	Industry	Tertiary	Household	Transport
Reduction of energy consumption	-21%	-23%	-40%	-40%	-14%
Reduction of CO ₂ emissions	-96%	-47%	-61%	-73%	-32%

The main problem of the scenario according to plan C is the public acceptance for nuclear power.

Further, the main swing in all plans about generated electricity occurs between nuclear plus fossil and wind; photovoltaic always stays a marginal contributor due to cost reasons.

Climate protection with nuclear phase out is expensive and limits CO₂-reduction to about 50% under realistic assumptions.

All model runs to define a 75% reduction scenario without nuclear energy or with nuclear retention only failed. It does not seem to be possible to build so many CCS power plants as required.

The VDI-Committee identified the following measures for the future:

1. Industry must be enabled to lower the final energy consumption by 30% at estimated increasing production up to a level of 180% in 2050. This requires more efficiency, use or reduction of exhaust heat, and permanent energy management.
2. The development of an economic and fuel saving carbon capture and storage technology for power plants and industry and of processes for the production of 2nd generation bio fuels must be promoted.
3. People's acceptance for CO₂ poor technologies must be promoted.
4. Households and tertiary sector must reduce their final energy consumption by totally 50%, especially by reducing electricity and heat consumption of old buildings (by means of insulation, improved installations, use of renewable energies).
5. The spectrum of available and economic technologies (hydrogen use in all sectors, nuclear fusion, and solar thermal power plants) has to be extended all the time.

Main findings

1. The important objective of GHG reduction can only be achieved by means of engineers' solutions in the next decades. It requires that all available technologies supporting this objective have to be used.
2. The objective of GHG reduction must be considered together with the objectives of security and economics of supply, environmental and social compatibility.
3. Electricity has a key role in GHG reduction measures, especially in transport.



Recommendations

1. Industrial restructuring from energy intensive to low consumption production should be considered with regard to employment in Germany. Migration of production sites is not a global solution.
2. For electricity supply retention and – if necessary – extension of nuclear power with immediate life time extension of existing nuclear plants is recommended. 2020 can be decided if and in what extent nuclear can be replaced by renewable capacity, for instance by solar thermal.
3. Although cargo in 2050 will probably twice as high as today the transport sector will have to lower final energy consumption by at least 15%. Political measures for avoidance of transport and for rail transport are urgently required.
4. Results of the climatologic research have to be proved and in taken into account for political decisions all the time.
5. GHG- Reduction has to be seen in an international scale; financial means have to be directed to sites at which the maximum effect can be achieved.

Acknowledgements

This project was elaborated by a VDI committee with support of scientific workers of the Institute of Energy Research at Jülich Research Centre.

Thanks also to the chair of the VDI e.V. for the financial support of this activity.